

Velodyne

OWNER'S MANUAL

ULD-15, ULD-18 Series II Subwoofer Systems

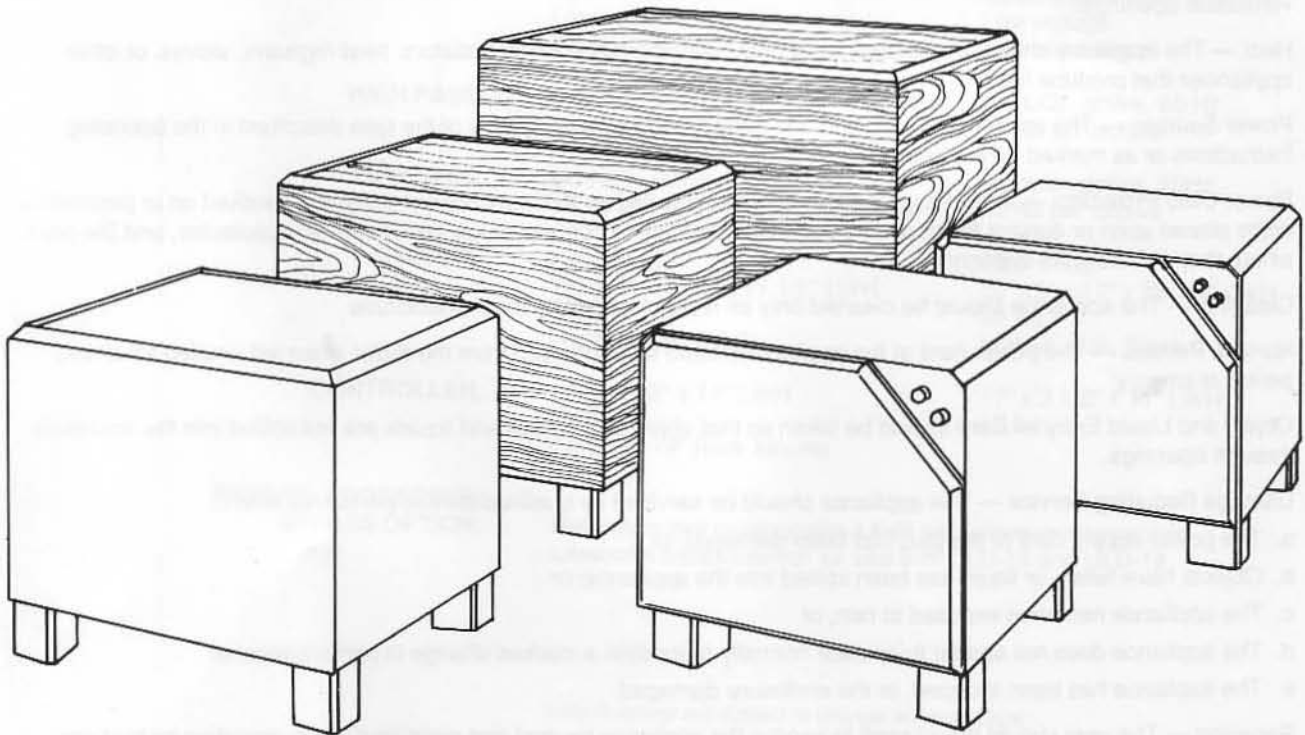

For Your Records:

Serial Number _____

Date of Purchase _____

Name of Store _____

OWNER'S MANUAL

VELODYNE ULD-15 AND ULD-18

SERIES II SUBWOOFER SYSTEMS

Congratulations on your purchase of a Velodyne ULD Series II Subwoofer System. This system represents the state of the art in accurate bass reproduction. Read and follow the instructions below to insure safe and proper system operation. Regardless of which installation configuration you choose, please carefully read the entire BASIC INSTALLATION section of this manual. Save this manual for future reference.

Warning: To prevent fire or shock hazard, do not expose this equipment to rain or moisture. To avoid electrical shock do not open speaker enclosure or amp chassis cover. Please observe all warnings on the equipment itself. There are no user serviceable parts inside. Please refer all service questions to your authorized Velodyne dealer.

Caution: Risk of hazardous energy. Your ULD Subwoofer System has a very powerful amplifier. Exercise extreme caution. Do not attempt any connection or disconnection with power on. Inspect speaker lead connections at controller and woofer terminal plate. Loose strands or frayed wire can cause a dangerous short circuit. Keep connections out of reach of children.

Prior To Installation: Your ULD Subwoofer System includes the following three separate components:

- 1) A cabinet incorporating the bass driver, servo interface jack, and speaker terminals. Observe the above caution notice.
- 2) A servo controller which includes the High Gain Servo correction circuitry, a 400 watt RMS amplifier, high and low pass crossovers, input and output jacks, level control, servo interface jack, and speaker terminals. Observe the above caution notice.
- 3) Cable kit with 25' phono cable for connection from controller to woofer cabinet, and a 3' patch cord for connecting the controller to your pre-amp. Speaker wire is not included.

Please unpack the system carefully, saving the carton and all packaging materials for future use. Remove all staples used to seal the carton as they can scratch the cabinet.

BASIC INSTALLATION

(Refer to Figure 1)

System Connection: The servo controller is designed to be installed between your pre-amplifier and amplifier (or between the amp and pre-amp sections of a receiver or integrated amp). *Make all connections with the servo controller unplugged.*

- 1) Install the included 3' patch cord between your pre-amp's output jacks and the servo controller (use FROM PRE AMP jacks).
- 2) Install a second patch cord between the servo controller (use TO POWER AMP jacks) and your amplifier's input jacks.

- 3) Install speaker cable between the terminals on the back of the servo controller and the terminals on the bottom of the woofer cabinet. Be certain that the connectors are red to red and black to black. Any heavy guage speaker wire may be used.

Caution: The speaker leads from the controller to the subwoofer *must* be installed from red to red and from black to black terminals. *Reverse connections will cause full power oscillation and may damage the woofer.* Poor connections, loose strands, or frayed wire can cause a dangerous short circuit. We recommend crimp-on spade lugs for positive connection.

The amplifier section of the controller generates some heat. Please maintain adequate ventilation.

The power cord should be routed in such a way that it will not be walked on, pinched, or compressed.

- 4) Install the supplied 25' phono cable between the SERVO INTERFACE jack on the servo controller and the single jack on the bottom of the woofer cabinet. If the length of this cable is inconvenient, you may replace it with any standard shielded phono cable.

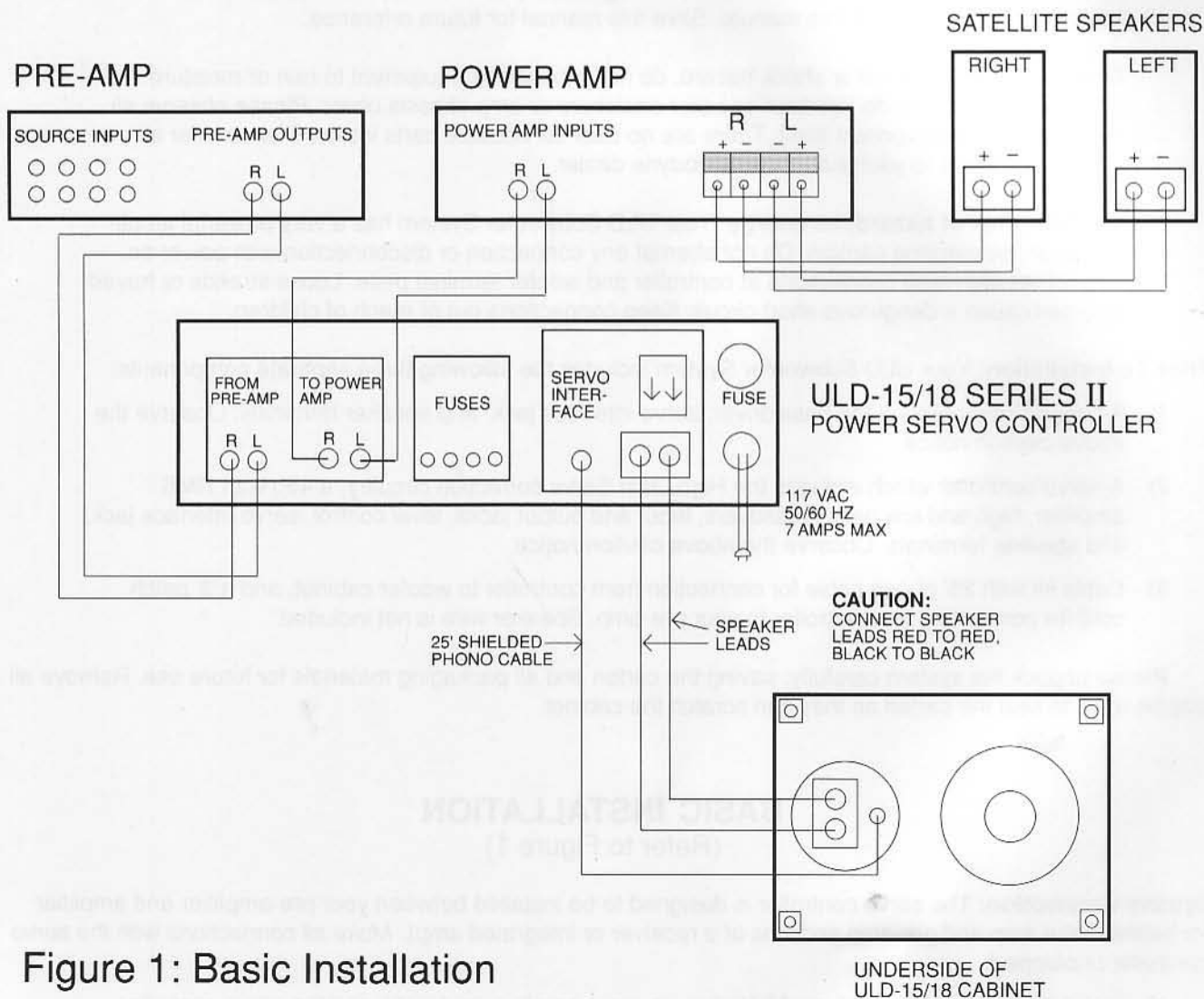

Figure 1: Basic Installation

Cabinet Placement: Your ULD subwoofer operates primarily at frequencies below 85 Hz. Due to the nondirectionality of these frequencies, it is not necessary to place the subwoofer equidistant from each of the satellite speakers. Note, however, that frequency response and output level can be greatly influenced by placement, depending on the acoustic variables of the room. Typically, the subwoofer will sound louder next to a wall or in a corner.

Due to the strength of the magnet in the ULD driver it is recommended that the unit be placed at least 4 feet from any television or other magnet-sensitive device such as a computer disk drive.

Adjusting Level Control: Once you have selected the proper location for your ULD subwoofer you will want to balance the overall output of your system. We recommend that you begin with the subwoofer level set to minimum. Play several selections of music and bring the subwoofer level up until the bass output matches the mids and highs to your satisfaction. You will notice that this takes some experimentation, especially if you are standing next to the subwoofer while making the adjustments.

Once you set the subwoofer level, the proportion of bass to midrange and treble output will remain constant. The Velodyne controller may be used to fine tune the bass output if desired.

Crossover Modification: Your ULD subwoofer has an active crossover network. Both the high and low pass filters are set for 85 Hz and feature 12 dB slopes. While either crossover point may be raised or lowered by your dealer at a nominal charge, we feel that the factory preset is the optimum crossover for most applications.

Installation of Crossover/Bypass Option: For audiophiles who prefer a passive high pass crossover, Velodyne offers an accessory unit which includes a 6 dB per octave crossover as well as a subwoofer bypass switch. The bypass function allows you to play your main speakers full range without the subwoofer. Figure 2 shows how to connect your ULD-15/18 with the Crossover/Bypass.

Contact your Velodyne dealer for additional information regarding this accessory (Velodyne part number 80-110FIN).

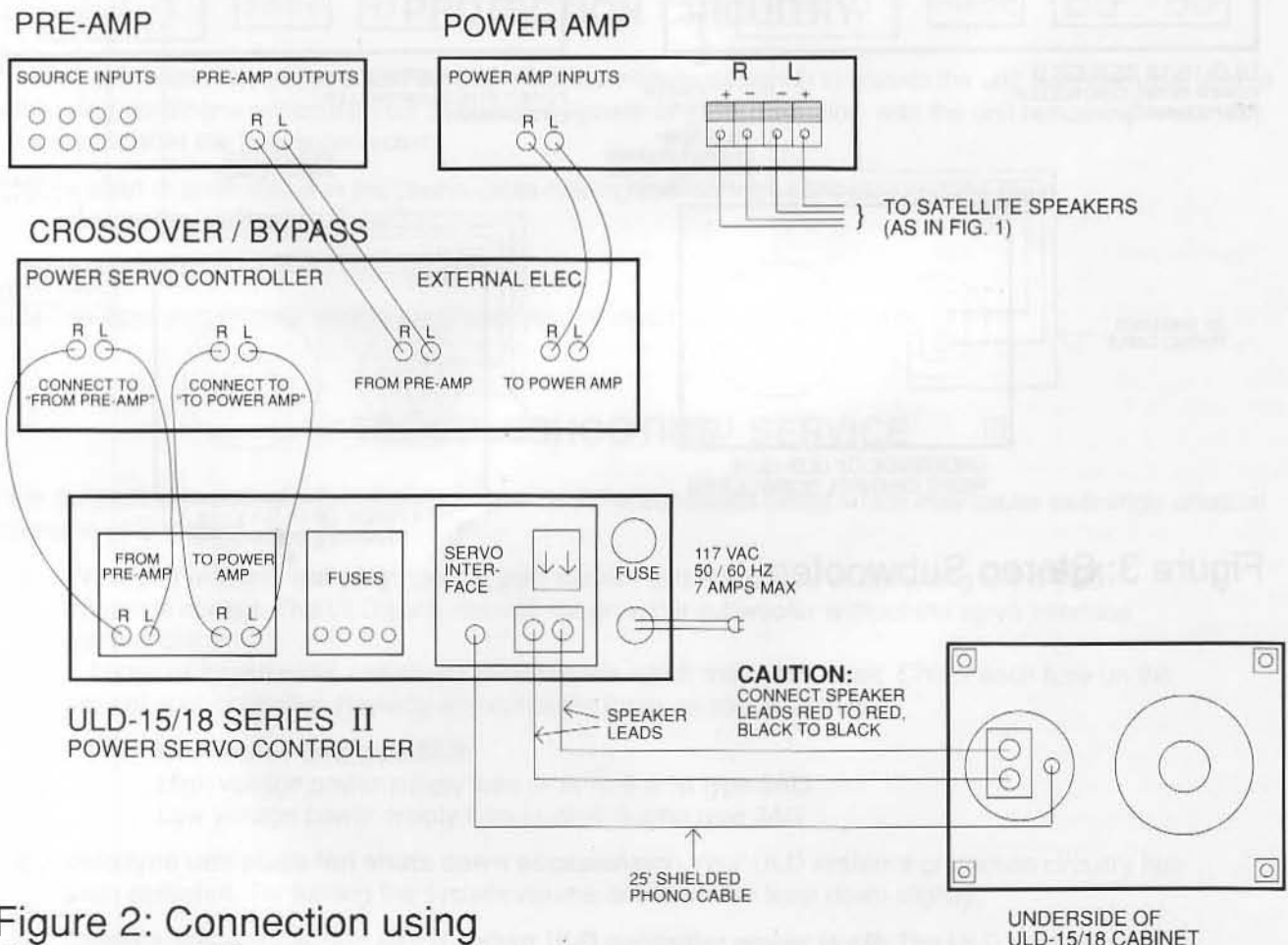

Figure 2: Connection using Crossover / Bypass Accessory

INSTALLING TWO ULD-15/18 SUBWOOFERS AS A STEREO PAIR

Although a single ULD Series Subwoofer dramatically enhances any quality audio system, many listeners demand the additional power and effect of stereo ULD-15/18s. Figure 3 shows the interconnection details. For stereo installation the right and left ULD Series Subwoofer cabinets should be located close to their respective satellite speakers.

Important Note: Each ULD-15/18 Subwoofer System consists of one controller and one driver that are shipped as a *matched set*. Listeners who own more than one ULD system must be sure that each subwoofer is only driven by its original controller. Compare serial numbers if you are ever unsure of which driver goes with which controller.

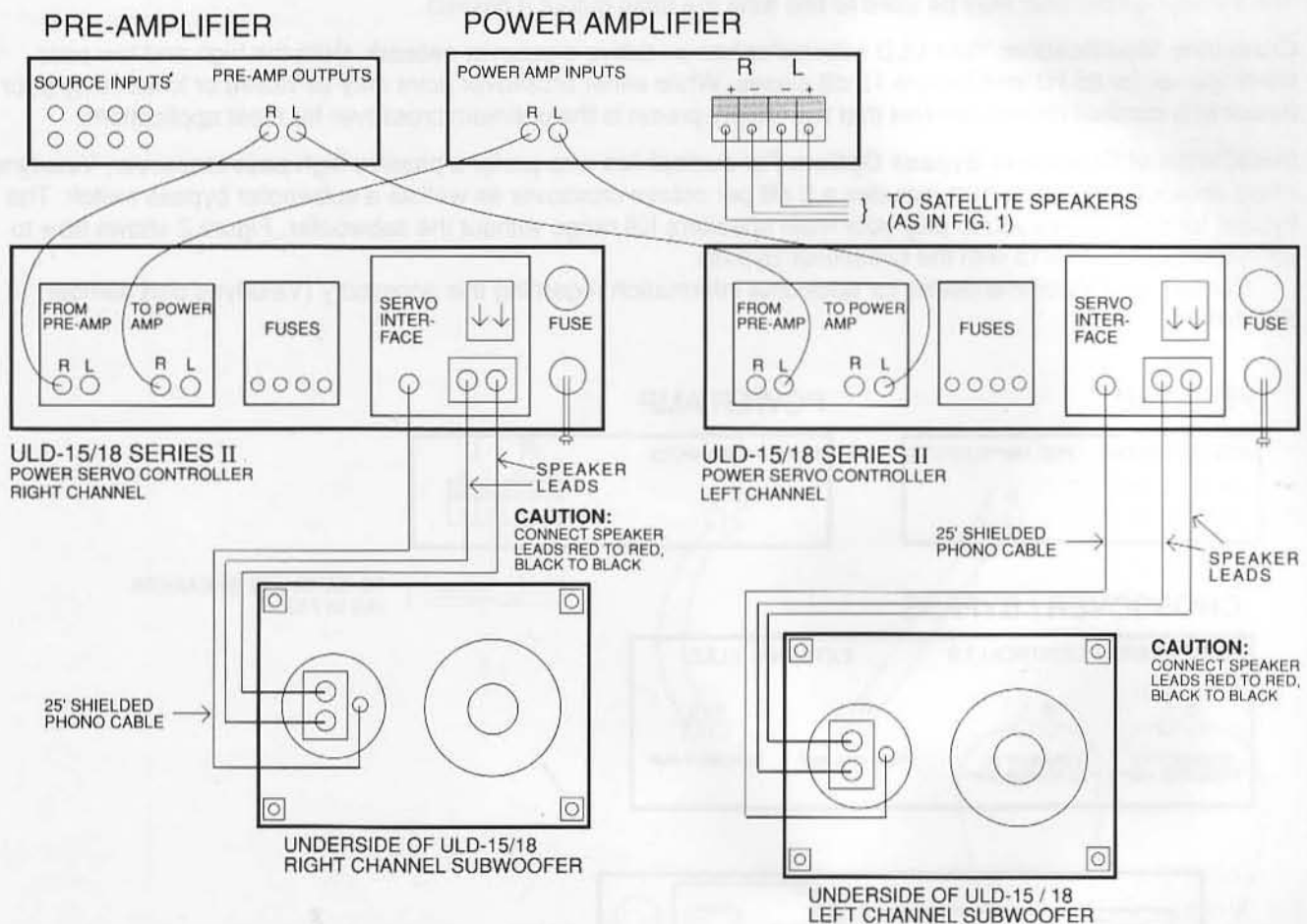

Figure 3: Stereo Subwoofers

OTHER INSTALLATION SCHEMES

Dual Subwoofers in Mono Mode: You may want to run a pair of ULD systems in monaural mode instead of stereo. Simply connect the one Subwoofer System (call this "System A") as shown in Figure 1, the basic installation. Then, using a Y-adaptor patch cord, tap the right and left signals between your pre-amp and System A. Feed these signals directly to the ULD controller of your second system ("System B"). Leave the TO POWER AMP outputs of System B unconnected. Please read the important note in the previous section concerning multiple-ULD system owners.

Connection to Mono Subwoofer Output: If your system has a single line-level subwoofer output, route a phono cable directly from this output to either of the right or left FROM PRE-AMP inputs on the ULD controller. Leave the unused input and both TO POWER AMP outputs unconnected.

CARE OF YOUR SUBWOOFER

If your subwoofer cabinet has a wood finish, we recommend using a clean soft cloth and a quality lemon oil. *Do not use wax.* If you have a painted model, use a damp cloth.

The controller has an anodized front panel which may be wiped with a clean soft cloth and diluted ammonia (such as Windex). Never use detergents or abrasives on any part of the system.

The ULD controller may be left on continuously without fear of long-term adverse effects. We do recommend that you turn off the unit during extended periods of nonuse.

PROTECTION CIRCUITRY

Your ULD subwoofer is equipped with several electrical circuits designed to protect the unit from damage. Any of the following conditions will cause your Subwoofer System to go into standby, with the unit remaining in standby for 5 seconds after the fault is corrected:

- 1) a short or open circuit in the phono cable running between the controller and the main subwoofer cabinet
- 2) a significant drop in the line voltage
- 3) an input signal which momentarily exceeds the dynamic range of the unit

TROUBLESHOOTING/ SERVICE

Before contacting your dealer for service, please note the conditions below which may cause seemingly unusual behavior in your system.

1. **Velodyne unit will not play:** Unplug your system and make sure all the wiring to the ULD system is correct. The ULD controller will not drive the subwoofer without the servo interface cable in place.

Loose or frayed wires can cause short circuits which may blow fuses. Check each fuse on the back of your controller. Replace any damaged fuses as specified below:

Line fuse: 7 amp type 3AG

High voltage power supply fuse (+ or -): 6 amp type 3AG

Low voltage power supply fuse (+ or -): 3 amp type 3AG

2. **Velodyne unit plays but shuts down occasionally:** Your ULD system's protection circuitry has been activated. Try turning the system volume or subwoofer level down slightly.
3. **Satellite speakers sound muddy when ULD controller power is off:** The ULD controller's high pass crossover is not bypassed when its power is turned off. Since the crossover is an active

one, it needs power to operate properly. If you wish to play your system with the Velodyne off, the ULD controller must be bypassed externally, either by direct wiring or with the optional Crossover/Bypass accessory.

4. **Subwoofer pops shortly after power on:** Your Velodyne has a built-in power-on delay that starts when you engage the power switch. After five seconds it turns itself on and a slight pop may be heard. This is normal operation.
5. **Satellite speakers pop when subwoofer is switched on:** Your satellite speakers may make a slight noise as the ULD controller's internal high-pass crossover is powered up. To prevent this problem, switch your Velodyne on before applying power to your power amp.

For service please contact your local Velodyne dealer. The following conditions *always* require service by qualified personnel:

- 1) If you wish to have the crossover point modified
- 2) If the power cord is damaged
- 3) If the unit does not appear to operate normally or exhibits a marked change in performance.
- 4) If the unit has been exposed to water

VELODYNE HGS SYSTEM

Velodyne's prime focus is in providing ultra low distortion loudspeaker systems that impress the dedicated audiophile as well as the casual listener. Velodyne's patented High Gain Servo (HGS) system insures that your new ULD series subwoofer will reproduce the music you enjoy without the excessive nonlinear distortions that plague conventional loudspeaker designs.

The Problem of Distortion

Nonlinear distortion is defined as any form of distortion that moves energy from one portion of the audio frequency spectrum to another. When a single tone is applied to a nonlinear system, the result is harmonic distortion, in which some of the energy leaves the system at integer multiples of the original input frequency. When multiple tones are applied to the same system, intermodulation tones are produced, usually as simple combinations of the input frequencies, i.e., sums and differences of integer multiples of the applied tones. In general, 3% nonlinear distortion is considered a reasonably small amount. This means that 3% of the total energy leaving a loudspeaker is at frequencies other than the intended pure tone applied to the input. Our tests, however, indicate that about 0.5% nonlinear distortion at normal listening levels must be achieved before the average listener is truly affected by an improvement in bass response.

In the reproduction of deep bass notes, loudspeakers suffer from a "double-whammy" when it comes to nonlinear distortion. First, most loudspeakers have much more than even 3% THD (Total Harmonic Distortion) at low frequencies. Even at 1 watt drive levels, many loudspeakers have 8 to 10% THD at 40 Hz. With the 50 watt drive levels needed to produce realistic bass intensity, these distortion figures rise to astonishing levels. Second, the distortion products produced by a nonlinear woofer are much easier to hear than is the fundamental frequency. Consider a speaker driven at 30 Hz with 5% 3rd harmonic distortion. If the 30 Hz tone is 90 dB SPL (Sound Pressure Level), equating to about 5 watts into a typical woofer, the 3rd harmonic, at 90 Hz, would be down 26 dB, or at 64 dB SPL. However, humans are more than 10 times as sensitive to sounds at 90 Hz than at 30 Hz. The nonlinear distortion produced by a woofer must be weighted by the sensitivity function of the human ear. When this is done, it becomes clear that even a small percentage of harmonic distortion is unacceptable in a bass driver. It is also clear that high-order (3rd, 4th, 5th, etc.) harmonic distortion products are more serious than are 2nd harmonic distortion products. These studies have led to the conclusion that 0.5% is the maximum tolerable amount of nonlinear distortion for a bass driver, and the less distortion the driver produces, the more capable it is of accurately reproducing live sounds.

Since most woofers today have at least 10% THD when 0.5% is the maximum tolerated, minor improvements in woofer technology are essentially ineffective. ULD Series Subwoofers have about 90 times less nonlinearity

than a typical 10 inch bookshelf speaker. They have about 3 times less distortion due to their greater size and power handling capability, and about 30 times less distortion due to the servo feedback loop. The improvement is even greater if one considers exceptionally loud and deep tones such as organ pedal notes.

An interesting result of this reduced distortion is that much of the bass, when played over a ULD Series Subwoofer, seems to actually be reduced. The truth, of course, is that the "missing" bass was never really there on the source material, and was never intended to be played by the artist. Distortion products introduced by conventional woofers actually make the entire bass spectrum sound louder.

Our Solution

The Velodyne ULD Series Subwoofer System produces sound in the same manner as any conventional loudspeaker: a cone-shaped piston is forced to move by means of a linear motor composed of a coil situated between the poles of a very strong permanent magnet. In the ULD Series, however, this linear motor is a servomotor, meaning that the motor is linked to the power amplifier as part of a control system. The basis for the control action is the signal obtained from an accelerometer which is rigidly fastened to the voice coil. The strategy of continuously monitoring the cone motion, and using this information as the basis for the corrective action, is called motional feedback. This feedback technique is illustrated in the system block diagram, Figure 4.

The signal into the system is a time varying voltage which is an exact analog of the desired acoustic output from the loudspeaker. The accelerometer output contains sufficient information to deduce the actual acoustical output of the woofer. The controller compares almost instantaneously how well the acoustic output matches the command signal coming in. If and when there is a deviation, the controller modifies the drive signal to the amplifier so that the acoustic output from the speaker is a true representation of the input.

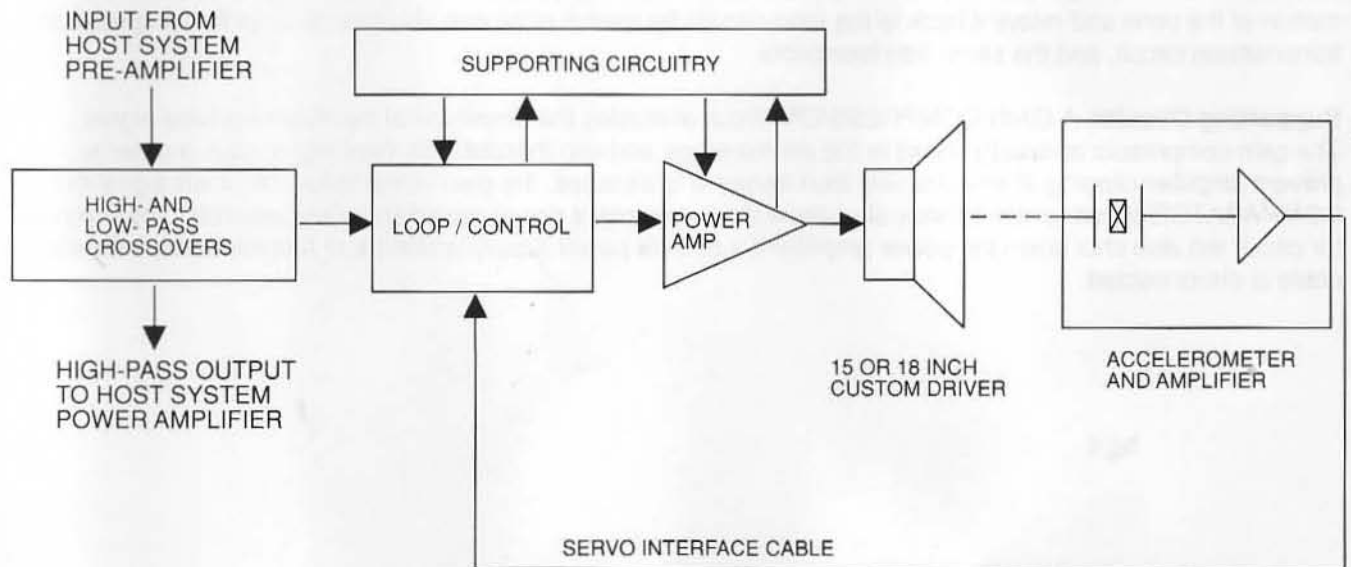

Figure 4: ULD Series System Block Diagram

In conventional loudspeakers, the drive signal into the speaker is virtually free from distortion but the speaker's acoustical output may be highly distorted. In ULD Series Subwoofers, the speaker coil drive signal is often highly distorted, or actually pre-distorted, in exactly such a way that the acoustic output from the speaker is free from distortion. Motional feedback has been used previously in an attempt to make small woofers sound like larger, more powerful ones. At Velodyne, the use of motional feedback is applied to make what is already a large and powerful woofer achieve a level of performance that has never before been reached in a home entertainment product.

HGS System Components

(Refer to Figure 4)

High and Low Pass Crossovers receive the incoming audio signals from your system pre-amp. Frequencies above 85 Hz (factory setting) are diverted to your power amplifier while frequencies from the right and left channels below 85 Hz are summed to monaural and passed on to subsequent stages in the subwoofer.

Loop/Control Stage. Incoming bass signals pass through a variable gain amplification stage designed to protect the subwoofer from being overdriven (see Supporting Circuits below). With a bit of added filtering, the bass signal is now ready to be compared with the feedback signal of the accelerometer. A composite signal is created which compensates for erroneous movement of the cone.

Power Amplifier. The 400-watt power amplifier runs very cool because of its two-level power supply switching method. The amplifier receives high voltage only when demanding musical peaks are detected.

15 or 18 Inch Driver. Although our HGS electronics play the most important role in reducing distortion, the ULD driver must be carefully engineered and constructed so as not to undo the work that the HGS electronics have done. A large magnet and voice coil are used to improve sensitivity, the cone is specifically shaped to reduce resonances, and ventilation holes are used liberally to eliminate whistling noises often associated with long-travel operation (essential for producing low frequencies at listenable volumes).

Accelerometer. Perhaps the most critical component of the HGS system, the accelerometer measures the motion of the cone and relays it back to the loop circuits by means of an onboard charge amplifier, a specialized transmission circuit, and the servo interface cable.

Supporting Circuits. A GAIN COMPRESSION circuit evaluates the amplitude of the incoming bass signal. The gain compressor is directly linked to the control stage and can thereby limit input signal gain in order to prevent amplifier clipping. If an extremely loud transient is detected, the gain compressor circuit will signal the COMPARATOR circuit to immediately shut down the subwoofer's power amplifier for five seconds. The comparator circuit will also shut down the power amplifier if it detects power supply problems or that the servo interface cable is disconnected.

VELODYNE, ULD-15, and ULD-18 are registered trademarks of Velodyne Acoustics, Inc.

Velodyne Acoustics, Inc.
1070 Commercial Street, Suite 101
San Jose Ca., 95112
(408) 436-7270

VELODYNE SUBWOOFER SYSTEM SPECIFICATIONS

	ULD-18 SERIES II	ULD-15 SERIES II
AMPLIFIER:	High Efficiency Discreet Class B 400-Watts RMS continuous	High Efficiency Discreet Class B 400-Watts RMS continuous
INPUT SENSITIVITY/ IMPEDANCE:	300 mV/20k ohms nominal	300 mV/20k ohms nominal
DAMPING FACTOR:	>1000	>1000
DRIVER:	18" 3/4" linear travel	15" 5/8" linear travel
VOICE COIL:	Edgewound copper 3"	Edgewound copper 3"
MAGNET:	216 oz.	216 oz.
CONE:	Resin impregnated fiber	Resin impregnated fiber
RESONANT FREQUENCY:	<4 Hz	<4 Hz
Q:	<.5	<.5
DISTORTION (20Hz @ 104dB)	<.5%	1%
VOLUME DISPLACEMENT:	130 ci	81 ci
FREQUENCY RESPONSE:	18-85 ±3 dB	18-85 ±3 dB
-3dB:	13 Hz	14 Hz
SERVO LOOP GAIN:	30 dB	30 dB
PROTECTION:	Open/short circuit Low voltage Excessive signal	Open/short circuit Low voltage Excessive signal
HIGH PASS:	Modular, active, 85 Hz 12 dB per octave	Modular, active, 85 Hz 12 dB per octave
LOW PASS:	Modular, active, 85Hz 12 dB per octave	Modular, active, 85Hz 12 dB per octave
CABINET:	Floor firing 31 1/2" x 23 1/2" x 21 1/2" LWH 105 lbs. Walnut, Oak, Black	Floor firing 22 1/2" x 17" x 18 1/4" LWH 90 lbs. Walnut, Oak, Black
CONTROLLER:	17" x 3 1/2" x 11" LWH 15 lbs. (Optional 19" Rack Mount)	17" x 3 1/2" x 11" LWH 15 lbs.
PASSIVE CROSSOVER/ BYPASS OPTION:	This accessory incorporates a 6dB per octave crossover and subwoofer bypass switch for use with ULD-15 and ULD-18.	

Specifications are subject to change without notice.

SAFETY INSTRUCTIONS



CAUTION: To reduce the risk of electric shock, do not remove cover (or back). No user-serviceable parts inside. Refer servicing to qualified service personnel.

The lightning flash with arrowhead symbol, within an equilateral triangle, is intended to alert the user to the presence of uninsulated "dangerous voltage" within the product's enclosure that may be of sufficient magnitude to constitute a risk of electric shock to persons.

The exclamation point within an equilateral triangle is intended to alert the user to the presence of important operating and maintenance (servicing) instructions in the literature accompanying the appliance.

1. Read Instructions — All the safety and operating instructions should be read before the appliance is operated.
2. Retain Instructions — The safety and operating instructions should be retained for future reference.
3. Heed Warnings — All warnings on the appliance and in the operating instructions should be adhered to.
4. Follow Instructions — All operating and use instructions should be followed.
5. Water and Moisture — The appliance should not be used near water — for example, near a bathtub, washbowl, kitchen sink, laundry tub, in a wet basement, or near a swimming pool, and the like.
6. Carts and Stands — The appliance should be used only with a cart or stand that is recommended by the manufacturer.
7. Wall or Ceiling Mounting — The appliance should be mounted to a wall or ceiling only as recommended by the manufacturer.
8. Ventilation — The appliance should be situated so that its location or position does not interfere with its proper ventilation. For example, the appliance should not be situated on a bed, sofa, rug, or similar surface that may block the ventilation openings; or, placed in a built-in installation, such as a bookcase or cabinet that may impede the flow of air through the ventilation openings.
9. Heat — The appliance should be situated away from heat sources such as radiators, heat registers, stoves, or other appliances that produce heat.
10. Power Sources — The appliance should be connected to a power supply only of the type described in the operating instructions or as marked on the appliance.
11. Power-Cord Protection — Power-supply cords should be routed so that they are not likely to be walked on or pinched by items placed upon or against them, paying particular attention to cords at plugs, convenience receptacles, and the point where they exit from the appliance.
12. Cleaning — The appliance should be cleaned only as recommended by the manufacturer.
13. Nonuse Periods — The power cord of the appliance should be unplugged from the outlet when left unused for a long period of time.
14. Object and Liquid Entry — Care should be taken so that objects do not fall and liquids are not spilled into the enclosure through openings.
15. Damage Requiring Service — The appliance should be serviced by qualified service personnel when:
 - a. The power-supply cord or the plug has been damaged; or
 - b. Objects have fallen, or liquid has been spilled into the appliance; or
 - c. The appliance has been exposed to rain; or
 - d. The appliance does not appear to operate normally or exhibits a marked change in performance; or
 - e. The appliance has been dropped, or the enclosure damaged.
16. Servicing — The user should not attempt to service the appliance beyond that described in the operating instructions. All other servicing should be referred to qualified service personnel.